

SUPPLEMENTARY REGULATIONS

RALLY HUNGARY

VESZPRÉM - BALATON

HUMDA



RALLY HUNGARY

RALLYHUNGARY.COM

2025.



HUMDA

VESZPRÉM
A KIRÁLYNÉK VÁROSA

TRP
HUNGARY

MITKO
for events



ENEOS
MOTOR OIL

HANKOOK
driving emotion

MICHELIN

MRF TYRES

PIRELLI

TABLE OF CONTENTS

page

1. INTRODUCTION	3
2. ORGANISATION	3
3. PROGRAMME	6
4. ENTRIES.....	7
5. INSURANCE	10
6. ADVERTISING AND IDENTIFICATION	11
7. TYRES	11
8. FUEL, REFUELLING	12
9. RECONNAISSANCE.....	12
10. ADMINISTRATIVE CHECKS	14
11. SCRUTINEERING, MARKING AND SEALING	14
12. OTHER PROCEDURES.....	16
13. IDENTIFICATION OF OFFICIALS	19
14. CLASSIFICATION AND PRIZES.....	19
15. FINAL CHECKS AND PROTESTS	20
Appendix 1 - Itinerary	21
Appendix 2 – Reconnaissance	24
Appendix 3 - CROs – names, photographs and duties schedule	25
Appendix 4 - Competition numbers and advertising	26
Appendix 5 – Extracts from FIA ISC Appendix L relating to overalls, helmets and any other safety requirements.....	28
Appendix 6 – SAS FITTING KIT MANUAL – RALLY CAR.....	29

1. INTRODUCTION

1.1 General

VI. Rally Hungary will be run in compliance with the International Sporting Code and its appendices, the 2025 FIA Regional Rally Sporting Regulations (further only FIA-RRSR), including appendices, the ASN Technical Regulations (only when related to national cars) the WADA/NADA Codes, and the FIA Anti-Doping Regulations, as amended from time to time. The National Road Traffic Regulations shall apply. Unless provided otherwise by these Supplementary Regulations, the provisions of the above Rules and Regulations shall apply. Any modifications, amendments and/or changes to these Supplementary Regulations will be announced only by numbered and dated Bulletins (issued by the organiser or the Stewards). The various documents will be written in English and Hungarian. In case of any discrepancy the English text will be binding.

The event is accompanied by a Hungarian Championship, with the ERC field starting at the front.

Additional information is published in the Rally Guide.

The FIA Regional Rally Championships Sporting Regulations can be found at:

<https://www.fia.com/regulation/category/117>

1.2 Surface

97.37 % gravel

2.63 % asphalt

1.3 Overall SS distance and the total distance of the itinerary

The total distance of the SS: 193,06 km (13 SS)

The total distance of the rally: 828,32 km

1.4 Name of the Rally

The official name of the rally is: VI. Rally Hungary

2. ORGANISATION

2.1 Eligibility

2.1.1 FIA classification

FIA European Rally Championship for Drivers and Co-Drivers

FIA European Rally Championship for Teams

FIA European Rally Championship for Tyre Suppliers

FIA ERC3 Championship for Drivers and Co-Drivers

FIA ERC4 Championship for Drivers and Co-Drivers

FIA Junior ERC Championship for Drivers

FIA Master ERC Championship for Drivers

2.1.2 Other titles for which the rally counts:

M-Sport Fiesta Rally3 Trophy

Hungarian Rally Championship

2.2 VISA numbers

FIA visa No.: 02ERC/250311

ASN Visa No.: K-0188/2025.03.10.

2.3 Organizer's name, address and contact details

Name:

Postal Address:

Permanent Office:

E-mail:

Web:

Localfixer Kft.

1054 Budapest, Akadémia utca. 14.

2310 Szigetszentmiklós, Gyári út 64.

rallyhungary@trpevents.hu

www.rallyhungary.com

2.4 Organisation Committee:

Chairman:
Members:

Kornél **Őry**
Dániel **Árvai**
Róbert **Lakatos**
Miklós **Lovay**
Krisztián **Berke**
Heriman **Widjaja**
Attila **Varga LLD**
Andrea **Zólyomi**

2.5 Stewards of the meeting:

Chairperson:
Members:

Arnas **Paliukenas** LTU
Joe **Corcoran** IRL
István **Móni** HUN

2.6 FIA Delegates & Observer:

FIA Sporting Delegate:
FIA Technical Delegate:
FIA Assistant Technical Delegate:
FIA Safety Delegate:

Miikka **Anttila** FIA
Emanuele **Saglia** FIA
Mohand **Abdelmoula** FIA
Benjamin **Schmidt** FIA

2.7 Senior officials

Event Director:
Event Sport Director:
Clerk of the Course:
Deputy CoC:
Assistant of the CoC:
Chief Safety Officer:
Deputy of Chief Safety Officer:
ASN Safety Delegate:
Secretary of the Rally:
Secretary to the Stewards
Service Park Manager:
Chief Results Officer:
Chief Rescue Officer:
Chief Timekeeper:
Chief Scrutineer:
Chief Medical Officer:
Press Relations Officer:
Environmental Coordinator:
Competitors' Relations Officers ERC:

Dániel **Árvai**
Róbert **Lakatos**
Miklós **Lovay**
Levente **Kovács**
Márton **Kálló**
Krisztián **Berke**
Melitta **Molnár**
László **Polgár**
Andrea **Zólyomi**
Éva **Galambosi**
Károly **Horváth**
József **Hauser**
Roland **Nagy**
Lajos **Boros**
Róbert **Groll**
Ádám **Radványi MD**
Anita **Tóth**
Gabi **Tóth**
Julianna **Nyirfás**
Szabolcs **Magyari- Beck**

2.8 HQ location and contact details

Place: Veszprém Aréna
H-8200 Veszprém, Kádártai út 5.
GPS: N47° 06.336' E17° 56.044'
E-mail: rallyhungary@trpevents.hu

Rally Office opening hours during the event:

Wednesday	07 May 2025	17:00-22:00
Thursday	08 May 2025	08:00-20:00
Friday	09 May 2025	08:00-21:00
Saturday	10 May 2025	08:00-21:00
Sunday	11 May 2025	08:00-21:00

RALLY HQ GPS:



Digital Notice Board (DNB):

During the event, individual and general communication between all Rally Officials (Rally Control/COC, Rally Secretariat, CRO, Stewards, Technical Staff etc.) and the competitors/crew members will primarily and as far as possible be conducted via Sportity App.

For this purpose, each competitor is required to nominate **ONE** official representative authorised for the purpose of receiving any official notifications. As some of these notifications can be issued while rally cars are on stages, this person can neither be the driver nor the co-driver. This person should be a team representative who is based in the Service Park during the event.

This contact (name, title, cellphone, email) must be nominated **at the latest on 30 April 2025** and sent by email to the Secretary of the Rally: **rallyhungary@trpevents.hu** and will be used both for general and individual communications.

As provided for in FIA ISC Art. 11.9.4 the Official Notice Board will be the Digital Official Notice Board (DNB) published on the event website: www.rallyhungary.com

There will be no physical official notice board. Additionally, rally documents will also be available in the **Sportity app** (downloadable for iOS devices on Appstore and for Android devices on Google Play): Password is **RH2025**

All competitors will receive push notifications to Sportity app about the publication of any documents on the digital notice board.

2.9 Location and opening times of Parc Fermé

Veszprém, Ady Endre u. 5.

09-13th May 2025

2.10 Location and opening times of the Press Centre

Place:

Veszprém Aréna

H-8200 Veszprém, Kádártai út 5.

GPS:

N47° 57.353' E21° 41.686'

Date and opening times:

Thursday	08 May 2025	08:00-20:00
Friday	09 May 2025	08:00-21:00
Saturday	10 May 2025	08:00-21:00
Sunday	11 May 2025	08:00-20:00



2.11 Location of the appointed hospitals

Main hospital:

Csolnoky Ferenc Kórház
Veszprém, Kórház u. 1., 8200

Back-up hospital:

Fejér Vármegyei Szent György Kórház
Székesfehérvár, Seregélyesi út 3, 8000

3. PROGRAMME

3.1 Schedule before rally week (All time CET)

Tuesday, 11 March 2025		
24:00	Publishing of the Supplementary regulations, entries open	web: www.rallyhungary.com
Tuesday, 18 March 2025		
24:00	Publishing the Rally Guide	web: www.rallyhungary.com
Thursday, 24 April 2025		
24:00	Closing date for entries	
24:00	Closing date for additional space and other requests for the service area	web: www.rallyhungary.com
24:00	Closing date for helicopter registration	web: www.rallyhungary.com
24:00	Issuing of electronic version of the road book, maps, recce videos and kmz-files	web: www.rallyhungary.com
Thursday, 01 May 2025		
14:00	Publication of the List of entries approved by the FIA	web: www.rallyhungary.com
Sunday, 04 May 2025		
24:00	Deadline of sending the Certificate of FIA eLearning course on the usage of the SAS tracker / FIA Emergency Console	e-mail: rallyhungary@trpevents.hu

3.2 Schedule during the rally week

Wednesday, 07 May 2025		
18:00 - 22:00	Administrative checks (sign-in)	Rally Office
18:00 - 22:00	Distribution of the roadbook Collection of individual event access codes for reconnaissance tracking app	Rally Office
16:00	Opening of the service Park (Veszprém)	See Art. 12.5 SR
20:00	Closing date for shakedown registration	Rally Office
Thursday, 08 May 2025		
07:00 - 23:00	Reconnaissance - Day 1	Details - Appendix 2
08:00	Opening of the service area (Veszprém)	See Art. 12.5 SR
08:00- 22:00	Opening of Press Centre and media accreditation	Veszprém, Veszprém Aréna
08:00- 12:00	Administrative checks (sign-in)	Rally Office
13:00- 20:00	Scrutineering of the cars, marking and sealing	Veszprém, TBA
18:30- 20:00	Promoter Competitor Photoshoot	Rally Office
20:00	Team managers meeting	Rally Office
Friday, 09 May 2025		
07:00 - 12:00	Reconnaissance - Day 2	Details - Appendix 2
09:00 - 10:00	Re-scrutineering	Service Area

11:00	Publication of the Amended entry list	DNB
11:30	Publication of the Starting list for the qualifying stage	DNB
11:00- 13:00	Free practice (FIA and ERC1 Priority drivers entered with Rally2 group cars)	Hajmáskér
14:01	Qualifying stage (FIA and ERC1 Priority drivers entered with Rally2 group cars)	Hajmáskér
15:10 – 16:10	Shakedown (for all ERC competitors)	Hajmáskér
16:00	Publication of Provisional Classification QS	DNB
16:30	Publication of Starting lists for LEG 1 Section 1	DNB
17:00	Publication of Starting lists for LEG 1 Section 2	DNB
17:37	Start of Leg 1 (Section 1) TC 0A	Veszprém, Service Area OUT
18:35	Finish of Leg 1 (Section 1) – TC 1 A	Veszprém, Parc Fermé IN
Saturday, 10 May 2025		
08:00	Start of Leg 1 (Section 2) – TC 1B	Veszprém, Parc Fermé OUT
19:22	Finish of Leg 1 (Section 3) – TC 7C	Veszprém, Parc Fermé IN
20:00	Publication of Starting list for Leg 2	DNB
Sunday, 11 May 2025		
08:25	Start of Leg 2 (Section 4) – TC 7D	Veszprém, Parc Fermé OUT
17:50	Finish of the rally – TC 13A	Veszprém, Finish podium
18:30	Prize-giving ceremony	Veszprém, Finish podium
18:40	Final Scrutineering	See Art. 12.8 SR
20:30	Posting of the Provisional classification	DNB

4. ENTRIES

4.1 Closing date for entries

Closing date for entries: **24th April 2025 at 24:00**

4.2 Entry procedure

Anyone wishing to take part in VI. RALLY HUNGARY must register on the FIA's online platform before the entries closing date.

Priority drivers must complete the electronic form available at the WEBSITE: <https://registrations.fia.com/rally>

Non-priority drivers must complete the electronic form available at the WEBSITE: <https://registrations.fia.com/erchun>

Please note that the FIA registration platform requires a user ID and a password to access the entry system. The FIA will need time to register you in the system and open your user account. Please do not wait until the last moment to make your entry in order not to miss the entry closing date. A duly completed electronic entry form must be sent before the closing date for entries.

Entries are only accepted if accompanied by the total amount of entry fee.

The administrative check will be organized remotely after the closing date of entries. All Entrants will get an e-mail with unique details, please pay attention for the incoming emails!

4.3 Number of accepted entrants and classes

- The number of entrants is limited by 80 cars in ERC

4.3.2 For participation of rally cars, Article 12 of the 2025 FIA Regional Rally Championships regulations will be followed.

Permitted groups and classes:

CLASSES	GROUPES / GROUPS
RC2	Groupe Rally2 Group Rally2 – Voitures du Groupe Rally2 conformes à l'Annexe J 2025, Art. 261 – Group Rally2 cars conforming to the 2025 Appendix J, Art. 261
	Groupe Rally2 Kit (VR4K) Group Rally2 Kit (VR4K) – Voitures équipées du Kit R4 conformes à l'Art. 260E de l'Annexe J 2025 – Cars fitted with R4 Kit conforming to the 2025 Appendix J, Art. 260E
	Groupe NR4 de plus de 2000 cm ³ Group NR4 over 2000cc – Voitures du Groupe N conformes à l'Art. 254 de l'Annexe J 2019 – Group N cars conforming to the 2019 Appendix J, Art. 254
	S2000-Rallye : atmosphérique 2.0 S2000-Rallye : 2.0 Atmospheric – Voitures Super 2000 (Annexe J, Art. 254A de l'Annexe J 2013) – Super 2000 cars (conforming to the 2013 Appendix J, Art. 254A)
Groupe R4 (VR4) (non valable en Europe) Group R4 (VR4) (not eligible in Europe) – Voitures du Groupe R4 conformes à l'Art. 260 de l'Annexe J 2018 – Group R4 cars conforming to the 2018 Appendix J, Art. 260	
RGT	Voitures RGT RGT cars – Voitures du Groupe RGT conformes à l'Art. 256 de l'Annexe J 2019 – Voitures du Groupe RGT conformes à l'Art. 256 de l'Annexe J 2025 – Group RGT cars conforming to the 2019 Appendix J, Art. 256 – Group RGT cars conforming to the 2025 Appendix J, Art. 256
RC3	Rally3 (atmo entre 1390 et 2000 cm ³ et turbo entre 927 et 1620 cm ³) Rally3 (atmo over 1390cc and up to 2000 cc and turbo over 927cc and up to 1620cc) – Voitures du Groupe Rally3 homologuées à partir du 01/01/2021 et conformes à l'Art. 260 de l'Annexe J 2025 – Group Rally3 cars homologated from 01/01/2021 and conforming to the 2025 Appendix J, Art. 260
RC4	Rally4 (atmo entre 1390 cm ³ et 2000 cm ³ et turbo entre 927 cm ³ et 1333 cm ³) Rally4 (atmo over 1390cc and up to 2000cc and turbo over 927cc and up to 1333cc) – Voitures du Groupe Rally4 homologuées à partir du 01/01/2019 et conformes à l'Art. 260 de l'Annexe J 2025 – Voitures du Groupe R2 homologuées avant le 31/12/2018 et conformes à l'Art. 260 de l'Annexe J 2018 – Group Rally4 cars homologated from 01/01/2019 and conforming to the 2025 Appendix J, Art. 260 – Group R2 cars homologated before 31/12/2018 and conforming to the 2018 Appendix J, Art. 260
	R3 (atmo entre 1600 cm ³ et 2000 cm ³ et turbo entre 1067 cm ³ et 1333 cm ³) R3 (atmo / over 1600cc and up to 2000cc and turbo over 1067cc and up to 1333cc) – Voitures du Groupe R homologuées avant le 31/12/2019 et conformes à l'Art. 260 de l'Annexe J 2019 – Group R cars homologated before 31/12/2019 and conforming to the 2019 Appendix J, Art. 260
	R3 (turbo jusqu'à 1620 cm ³ / nominal) R3 (turbo / up to 1620cc / nominal) – Voitures du Groupe R homologuées avant le 31/12/2019 et conformes à l'Art. 260D de l'Annexe J 2019 – Group R cars homologated before 31/12/2019 and conforming to the 2019 Appendix J, Art. 260D
	Groupe A jusqu'à 2000 cm ³ Group A up to 2000cc – Voitures du Groupe A conformes à l'Art. 255 de l'Annexe J 2019 – Group A cars conforming to the 2019 Appendix J, Art. 255
RC5	Rally5 (atmo jusqu'à 1600 cm ³ et turbo jusqu'à 1333 cm ³) Rally5 (atmo up to 1600cc and turbo up to 1333cc) – Voitures du Groupe Rally5 homologuées à partir du 01/01/2019 et conformes à l'Art. 260 de l'Annexe J 2025 – Group Rally5 cars homologated from 01/01/2019 and conforming to the 2025 Appendix J, Art. 260
	Rally5-Kit (atmo ou turbo jusqu'à 1600 cm ³) Rally5-Kit (atmo or turbo up to 1600cc) – Voitures du Groupe Rally5-Kit homologuées à partir du 01/01/2024 et conformes à l'Art. 260B de l'Annexe J 2025 – Group Rally5-Kit cars homologated from 01/01/2024 and conforming to the 2025 Appendix J, Art. 260B
	Rally5 (atmo jusqu'à 1600 cm ³ et turbo jusqu'à 1067 cm ³) Rally5 (atmo up to 1600cc and turbo up to 1067cc) – Voitures du Groupe R1 homologuées avant le 31/12/2018 et conformes à l'Art. 260 de l'Annexe J 2018 – Group R1 cars homologated before 31/12/2018 and conforming to the 2018 Appendix J, Art. 260

4.4 Entry fees including insurance (see art. 5.2.):

Entry fees (As per national law 27% VAT must be added to all amount below)

ERC Registered entrant		ERC Priority			
		ERC1	ERC3	ERC 4	M-SPORT Trophy
Legal entrant	With the optional advertising	4000 €	3400 €	2800 €	1500 €
	Without the optional advertising	6000 €	5400 €	4800 €	3000 €
Private entrant	With the optional advertising	3500 €	2900 €	2300 €	1500 €
	Without the optional advertising	5500 €	4900 €	4300 €	3000 €

Entry fees for all registered Junior ERC competitors are waived for VI. Rally Hungary

ERC non-registered entrant		Class		
		RC2/RGT	RC4	RC4/RC5
Legal entrant	With the optional advertising	4000 €	3400 €	2800 €
	Without the optional advertising	6000 €	5400 €	4800 €
Private entrant	With the optional advertising	3500 €	2900 €	2300 €
	Without the optional advertising	5500 €	4900 €	4300 €

Private entrant: A member of the crew, holding a personal entrant license, who enters his / her own car and competes under his / her own name.

Legal entrant: A Company, a Team or a Sporting Association holding a legal entrant's license who enters one or more cars.

4.5 Payment details

Entry fee has to be paid by bank transfer.

Account holder: Localfixer Kft.
Bank name: Otp Bank Nyrt.
Bank address: 1052 Budapest, Deak Ferenc utca 7-9.
IBAN: HU56 1176 3055 6118 7885 0000 0000
SWIFT: OTPVHUBB

PLEASE WRITE INTO THE BANK TRANSFER'S SUBJECT THE COMPETITOR'S NAME

ANY BANK CHARGES INCURRED MUST BE PAID BY THE ENTRANTS IN ADDITION TO THE ENTRY FEES!

If a team wants to receive an invoice prior to making the payment for the entry fee, the team must send all invoice details to rallyhungary@trpevents.hu, including valid VAT nr. if the company has one.

4.6 Other fees:

Entry for Reconnaissance	300 EUR
Additional auxiliary plate	200 EUR

4.7 Acceptance of Entry form

An entry application will be accepted only if accompanied by the total entry fees or by a receipt issued by the competitor's ASN. The organizer has the right to refuse entry of a driver except for FIA and ERC registered drivers.

4.8 Entry packages

Categories	Legal entry	Private entry	ERC Team Junior Entry (ERC4)
Vehicle plates per car			
• VIP / Quest plates	1	0	0
• Service plates	2	1	1
• Auxiliary plates	1	1	0
Services			
• Access to ERC Service area	Yes	Yes	Yes
Area in Service Park ERC Registered Team	150 m ² for 1 car +50 m ² for each add. car	100 m ² for 1 car +50 m ² for each add. car	90 m ² for 1 car +50 m ² for each add. car
• Area in Service Park ERC NON Registered	120 m ² for 1 car +50 m ² for each add. car	80 m ² for 1 car +50 m ² for each add. car	70 m ² for 1 car +50 m ² for each add. car
Printed materials per car			
• Roadbook sets • Regulations • Programmes	2	1	1
Non permanent ERC Passes per car			
• Crew	2	2	2
• Team	8	6	6

4.9 Refunds

Entry fees will be fully refunded:

- to candidates whose entry has not been accepted
- in the case of the rally not taking place.
- In the case of force majeure for the competitor, after investigation by the Stewards

The Organiser may refund up to 50% of the entry fee to those competitors who, for reason of "force majeure" (duly certified by their ASN), were unable to start the rally. The application for a refund, stating the reason for not starting, must reach the Organiser in writing to rallyhungary@trpevents.hu before the start of the Administrative Checks. Bank account details must be included.

5. INSURANCE

5.1 Insurance Coverage for the Organizer

5.1.1 Organizer`s liability insurance

The Organiser has concluded an insurance contract with Groupama Zrt.. The insurance is covering damage caused to a third party during the event up to TBA €. The insurance period is from **07/05/2025**.

5.2 Damage caused to third party

A part of the insurance contract concluded with Nexus Kft. is coverage for damages caused to a third party. However, damages caused by drivers among themselves are not covered by this contract.

5.2.1 Car third party liability insurance

All crews at Administrative Check have to hand in a valid motor third party liability insurance policy International Green Card for their car. Without this card, the crew won't be permitted to start.

5.3 Insurance Coverage for the competitors and crews

All the drivers and co-drivers are obliged to arrange their accident insurance. The proof should be

documented on request at administrative check. The insurance of foreign crews has to cover the costs of possible medical treatment in Hungary. Insurance cover must start from Free Practice / Shakedown until Parc fermé after the finish of the rally.

5.4 Damage Reporting

The crews are obliged to notify the organizer about the damage caused on the track by their car by the end of the event at the latest. Violation of this duty stands for summoning the competitor and involved crew to a disciplinary committee.

5.5 Insurance Coverage Exclusions

Auxiliary vehicles, cars dedicated to reconnaissance, and vehicles with special labels issued by the organizer are not covered by the provided rally insurance (except for insured organizer's cars) and those are always going on their responsibility.

6. ADVERTISING AND IDENTIFICATION

6.1 Compulsory advertising

- A - starting numbers
- B - rally plates
- C - rear window panel

6.2 Optional advertising proposed by organizer

The optional advertising will be issued by a bulletin before the closing date of entries.

The organizer reserves the following places which must remain free:

- D - panel 67 x 20 cm under the side door starting number
- E - panel 67 x 20 cm under the side door starting number

The placement of advertisings proposed by the organizer is given in Appendix 4 of these supplementary regulations.

6.3 Loss or removal of advertising

If there is ascertained at any point during the rally that an advertising sticker (or any other type of advertisement) supplied by the organizer is missing from a car then the crew shall be penalized with a fine of 400 € by the CoC for each missing advertisement or if the advertisement is modified or not placed according to the Appendix 4 SR.

6.4 Competition numbers and rally plates

Competition numbers and rally plates according to Article 27 of FIA RRSR supplied by the organizer must appear on both front doors of the car during the whole rally. If it is ascertained at any time during the rally that:

a competition number or one rally plate is missing, this will be penalized by 100 € by the CoC.

both competition numbers on front doors or both rally plates are missing; this will be reported to the Stewards.

6.5. Driver's and Co-driver's names

The first initial(s) and surname of both driver and co-driver, followed by the national flags of the country of the ASN from which they have obtained their licenses, must appear on the rear side window on both sides of the car, adjacent to the competition number. The names must be:

In white Helvetica.

In upper case for the initial(s) and the first letter of each name with the remainder in lower case.

6 cm high (upper case letters) and with a stroke width of 1.0 cm. The driver's name shall be the upper name on both sides of the car.

7. TYRES

7.1 At all times during the event in Hungary, the tread depth of the tyres fitted on the car, must not be less than 1.6 mm. All tyres used during the rally must conform with RRSR Art. 13 and with Appendix V.

Tyres used for reconnaissance can only be road-homologated series production tires.

7.1.1 Tyre quantity for competitors:

For all drivers entered in class **RC2, RGT**, a maximum of **16 tyres** may be used.

For all drivers entered in class **RC3, RC4** and **RC5**, a maximum of **12 tyres** may be used.

For competitors eligible to take part in Qualifying, tyres will be taken from the overall quantity as per

Art. V1a 15.1, except the spare wheel(s) fitted in the car.
For Free Practice and Shakedown tyres will not count from the overall quantity.

Any breach of the tyre regulations will be submitted to the Stewards who may impose a penalty according to art. 12.1 and 12.2 of the FIA International Sporting Code.
FIA-approved barcode is compulsory and must always be visible from outside the car.

7.1.2 Eligible tyres for the ERC Junior Championships

For the ERC Junior Championships, only Hankook tyres are eligible.
The maximum quantity for Junior ERC competitors for the whole event is 12 tyres to be chosen from the list below:

Dimension	Pattern	Name	Usage	Max. availability
175/70R15	R211	G33	Hard	12
175/70R15	R211	G73	Soft	6

8. FUEL, REFUELLING

8.1 Fuel

Fuel must comply with Appendix J (Article 252.9).

8.2 Refueling

Crews may refuel only in the designated refueling zones mentioned in the roadbook
Junior ERC: Competitors in the Junior ERC Championship must use fuel from the filling station described below. Service crews are allowed to fill this fuel in their canisters and refuel Junior ERC cars in rally refuel areas.

OMV Filling Station

H-8200, Veszprém, Külső-Kádártai Str 2
GPS: N47° 06.293' E17° 55.869'

Map from the service: t.ly/LCYq8

Only RON 100 petrol is allowed.

Refuel Area:

Refuel Area Veszprém: at the exit of the Service Park
Refuel Area operates on Friday 9th May from 10:00 to 21:00
Refuel Area operates on 10th and 11th of May according to roadbook and itinerary.

Remote Refuel Area: Ajka, url: <https://maps.app.goo.gl/Z1gmrGbDKBA97akC8>
Recommended route to Remote Refuel: <https://maps.app.goo.gl/QLfQvng245yAc8JM9>
Remote Refuel Area operates on 10th of May according to roadbook and itinerary.

During refueling, transporting fuel service crews have to follow the follow the Hungarian laws.

8.3 Refuel zone – Spill kit

All competitors and team members are responsible for running their refueling operation and protecting the ground against spills. Therefore, it is their responsibility to protect the ground with an environmental mat which shall be composed of an absorbent upper part, and an impermeable lower part, following art. 61.2.4 - FIA RRSR

9. RECONNAISSANCE

9.1 Reconnaissance registration

Before the beginning of reconnaissance, each crew must inform and give the details of the car that will be used during the reconnaissance period (make, model, registration plate).
The crew will receive an identification sticker for its car to be used during the reconnaissance period

as well as a timecard.

Reconnaissances schedule and passage will be monitored using the STATUS AWARENESS SYSTEM (SAS), see Art. 9.4 of these Supplementary Regulations.

Starting number must be affixed in the right upper part of the windscreen and in both rear side windows during reconnaissance at all the times. Any change of the car must be announced to the organizer in time. The reconnaissance timecard must be returned to the organizer at the end of reconnaissance at HQ.

9.2 The reconnaissance schedule is given in Appendix 2 SR.

9.3 Reconnaissance rules

The crews are obliged to follow all reconnaissance rules specified in the FIA-RRSR and these supplementary regulations.

9.3.1 Reconnaissance will be organized in compliance with art. 35 of the FIA-RRSR and only series production cars conforming to art. 35.1 of FIA -RRSR must be performed.

9.3.2 Any presence of driver or co-driver on the route of special stages during the period of three months before the start of the rally shall be regarded as performed reconnaissance. Drivers, who for whatever reason enter the area used for the Rally Hungary during that period, must promptly inform the Clerk of the Course (M. Lovay, tel.: +36304423060), excluding drivers living in that area, or working there. These restrictions apply to all who wish to attend the rally regardless of whether they already sent the entry form or received the supplementary regulations.

9.3.3 Reconnaissance is restricted to **2 passes** in the same special stage. **Crews are forbidden to drive in the opposite direction to that of the special stages, except for route areas specified in the reconnaissance roadbook.**

Control will be done by GPS tracking and rally officials, who will observe and control Reconnaissance in place. The crews must stop at these controls and present their reconnaissance timecard.

9.3.4 The progress of the reconnaissance will be monitored via GPS system, by the Hungarian police and other rally officials. The maximum speed limitations during reconnaissance follow the Hungarian traffic regulations. **Maximum speed allowed during reconnaissance is 70 km/h on special stages, unless a lower speed limit is indicated by traffic signs or by written instructions in the Road Book or Bulletin.** Breaking the rules and mainly exceeding the speed limits will be controlled and fined by the Hungary police according to standard procedures. Evaluation of the GPS data is within the competence of the Clerk of the Course. If there will be found that the reconnaissance vehicle is not equipped with a working tracking system, the crew will be penalized according to the Art. 9.3.5 SR.

9.3.5 Driving conduct

Entrants must follow Art. 34 of FIA RRSR.

Illegal reconnaissance performed out of the schedule or performing more passages than permitted will be reported to the stewards.

Speeding during reconnaissance and the rally will incur a fine applied by the CoC as follows:

Per km per hour over the speed limit: **€ 25**

- Other traffic infringements during reconnaissance will incur a fine applied by the Stewards.
- The amount of the fines will be unaltered by any fine imposed by the police.
- The fine will be doubled in case of a second offense committed during reconnaissance in the same rally.

Penalties for infringements during the competition element of the rally:

- a) First infringement:
 - Speeding: A fine of €25 per km over the speed limit, applied by the clerk of the course,
 - Other than speeding: A penalty will be applied by the Stewards.
- b) Second infringement:
 - Speeding: A fine of €50 per km over the speed limit, applied by the clerk of the course,
 - Other than speeding: A penalty will be applied by the Stewards.
- c) Third infringement: A 5-minute time penalty applied by the clerk of the course.
- d) Fourth infringement: Disqualification applied only by the Stewards.

9.4 Tracking system for reconnaissance

All reconnaissance cars must be equipped for reconnaissance with a smartphone-based application RS Lite developed by the FIA official supplier STATUS AWARENESS SYSTEM (SAS). The free App can be downloaded from Google Play or AppStore. SAS will distribute individual event access codes during the Reconnaissance materials distribution in Rally HQ (SAS Office). Competitors are responsible for having a IOS or Android device capable of using the App with GPS tracking and a battery lasting the entirety of reconnaissance time. Considerations should be made to make sure the smartphone or tablet can be charged and there are no 3rd party applications that disable GPS tracking.

Reconnaissance tracking system service has a cost per entered crew of 20 Euro, to be paid at Rally office when getting the reconnaissance code.

The progress of the Reconnaissance will be monitored via GPS system, by rally officials. Evaluation of the GPS data is within the competence of Clerk of the Course. Reconnaissance cars not equipped with a working RS Lite App will be reported to the Stewards.

10. ADMINISTRATIVE CHECKS

Administrative checks

Place: Rally Office, Veszprém Aréna
Date / Time : According to Art. 3.

Crews are obliged to make administrative checks before their time for scrutineering.

The administrative check will be organized remotely after the closing date of entries. All Entrants will get an e-mail with unique details, please pay attention for the incoming emails!

Documents to be checked online:

- Entry confirmation – filled technical card (sent by mail after entry deadline)
- Entry form duly signed by the competitor and drivers;
- Payment receipt of the total entry fee (to ensure that payment is duly received before the close of entries)
- Valid competitor's license;
- Valid driver's and co-driver's competition licenses;
- Valid driver's and co-driver's driving licenses;
- ASN authorization (mandatory for all foreign competitors);
- Driver's Declaration and undertakings forms, signed by the driver and the co-driver
- Valid car insurance policy, car registration documents (green card);
- Authorization of the car owner in case he is not one of the drivers;
- Photocopy of the page of the homologation form for the entered car indicating number, group, and cylinder capacity;
- Valid on active leisure risks personal accident insurance for all non-EU drivers;
- Certificate of completion for the FIA eLearning Course on FIA Safety Tracking Device (Driver & Codriver) see Art 11.8.3

Notwithstanding the 2025 FIA Regional Rally Sporting Regulations, Art. 30.1, drivers and co-drivers are not required to report personally to the administrative checks.

If any document is missing, or not approved, the secretariat calls for replacement. If there is no way to send it by e-mail, the entrant must present the correct document in the administrative check time window.

Crews must present their driving licenses during Roadbook issuing.

11. SCRUTINEERING, MARKING AND SEALING

11.1 Scrutineering

Place: TBA
GPS: TBA
Date / Time: According to Art. 3.

The schedule for scrutineering will be published in a bulletin on the Digital Notice Board of the rally. Any delay or early arrival at scrutineering will be penalized by 40 € for every 5 minutes. If the delay exceeds 30 min the crew will be reported to the Stewards.

The team must bring also a filled technical card confirmed from the administrative check.

According to the FIA 2025 ERC Sporting Regulations:

- All FIA and ERC priority drivers must seal their transmissions and spares.
- All cars must have an engine block marked.
- All cars equipped with a turbocharger and their spares must be marked.
- For drivers entered with a Rally2 car complying with 2025 Appendix J, Art. 261, it will be possible to use the old part after applying a joker (except reliability and safety jokers).

11.2 Mud flaps

Mandatory - According to Appendix J Article 252.7.7

11.3 Windows

Following Appendix J Art. 253.11, the use of silvered or tinted films is authorized, on the rear side windows, on the rear window, and the sunroof. Silvered or tinted films fitted on rear side windows must have an opening equivalent to the surface of a circle of 70 mm in diameter.

11.4 Safety equipment of crews

Every competitor is obliged to put forward full clothes, which will be used including helmets and FHR system. The agreement will be checked with chap. III Appendix L ISC and with technical regulations. Drivers and co-drivers who wear full-face helmets must be able to pass the following test to ensure that appropriate access to the airway of an injured driver is possible:

- the driver is to be seated in his car, with helmet and FIA-approved head restraint in place and attached and safety harness buckled.
- with the help of two rescuers, the chief medical officer of the competition (or, if present, the FIA medical delegate), must be able to remove the helmet with the driver's head maintained permanently in a neutral position.

If this is impossible, the driver will be required to wear an open-face helmet, according to Appendix 5.

11.5 Outside noise level of cars

All cars must be equipped with a stable exhaust silencer. The outside noise level measured by the stationary method may not exceed 102 dB(A) for all cars. (A/slow) The noise level will be measured at 3500 revs/min. in petrol engine cars and at 2500 rpm. in diesel engine cars.

The noise level will be measured during scrutineering and eventually at any point during the rally. Any exceeding of noise limit during scrutineering results in start refusal, any exceeding of noise limit in the course of the rally will be reported to the Stewards who may apply sanctions according to the art. 12.1 and 12.2 of the FIA International Sporting Code.

11.5.1 Catalytic converters

All vehicles must be obligatorily equipped with a homologated catalytic converter.

For missing, incomplete, or ineffective catalytic converters identified during scrutineering, the crew shall be refused a start. A car with a missing or incomplete catalytic converter during rally shall be reported to the Stewards, who may impose penalty following art. 12.1 and 12.2 of the FIA International Sporting Code.

11.5.2 Car lighting

In Hungary, it is obligatory to use a headlamp in liaison road sections between special stages. It is possible to use car lighting only through the original fitted and auxiliary headlamps with EHK ("E") homologation. Headlamps without homologation cannot be used during connection road sections. Complying with this provision will be checked by judges of fact. Any infringement will be reported to the Stewards who may impose sanctions complying art. 12.1 and 12.2 of the FIA International Sporting Code.

11.6 Obligatory monitoring device (GPS)

According to Appendix 6.

11.7 On-board cameras

The competitor of any car which carries an on-board camera must have the prior agreement of the ERC Promoter. Authorized cameras will be identified by an adhesive decal and must be mounted in the car at the time of Scrutineering.

Competitors wishing to use an on-board camera must apply via the **ERC Accreditation Portal** at least one week before the start of reconnaissance.

Those registering for an OBC for the first time in the 2025 ERC Season should first use this link: <https://bit.ly/OBC2025Registration>.

Documentation can be downloaded from the championship Sportivity account – FIAERCcomp.

11.8 Installation of Rally Safety Tracking System

11.8.1 All cars must be fitted with the SAS Safety Tracking System. Any competitor with a competition car without properly mounted and fully operational the SAS Safety Tracking System will not be authorized to start: Free Practice, Qualifying Stage, Shakedown and the Rally.

11.8.2 Competitors will receive SAS Safety Tracking System in Rally HQ (SAS Office) during registration for Reconnaissance. Systems may be collected either by the crew or a representative. **No deposit will be collected** for the rally safety tracking equipment, but all the damage caused will be invoiced afterwards.

11.8.3 Competitors must have installed the SAS Safety Tracking System in their rally cars before the car is brought to Scrutineering. The system will be checked during Scrutineering. For installation and operating instructions see Appendix 6.

All drivers and co-drivers entered in this event must complete the FIA eLearning course on the usage of the SAS tracker / FIA Emergency Console. The assessment is available on the website: <https://elearning.fia.com/learn/register> in English and French. It is compulsory to complete the course and present the certificate at Documentation control.

Instructions for completing the course will be sent to all entered crews by e-mail after the entry closing date. It is compulsory to complete the course and send the certificate to e-mail rallyhungary@trpevents.hu by **04.05.2025** at 24:00 CET at the latest. Additionally, the certificate must be presented at the Administrative Checks.

11.8.4 SAS Safety Tracking System devices can be removed in the Final Parc Fermé by the crew or maximum one team member under supervision of a Scrutineer and returned to SAS Office no later than 30 minutes after the opening of the Final Parc Fermé. Should a crew retire, the equipment must be returned immediately to SAS.

12. OTHER PROCEDURES

12.1 Start procedure and order

12.1.1 Start of the rally

On the Digital notice board (in given times according to SR Program) there will be published starting order for:

Name	TC	Description	Start order
Qualifying	TC QS	FIA, ERC1 Priority drivers with Rally2 cars with 2 minutes interval	
Leg 1 - Section 1	TC 0A	Reversed starting order according to starting numbers in 2 minutes intervals.	ERC, HRC*
Leg 1 - Section 2	TC 1B	According to Art 41 of RRSR	ERC, HRC*
Leg 2 - Section 3	TC 7E	According to Art 41 of RRSR	ERC, HRC*

*HRC: Hungarian Rally Championship

Time Cards will be collected at the following time controls: **Technical Zone IN after Qualifying, 1A, 4A, 7A, 7D, 10A, 12A, 13C, Parc Fermé IN**

12.1.2 Ceremonial start

There will be no Ceremonial Start.

12.1.3 Restart after retirement

Any crew which has failed to complete SS1 SSS Királyszentistván - Road Section (Section 1 of Leg 1) may start Section 2 of Leg 1. The car must report to the overnight Parc Fermé prior to the next Section no later than 1 hour before the scheduled start of Section 2. Re-scrutineering will be 1 hour before the start of the 1st driver into Section 2 of Leg 1.

Any crew which has failed to complete Leg 1 may be assumed to re-start the rally from the start of the next Leg unless they confirm otherwise in writing to the clerk of the course. For a new start the condition according to the art. 54 FIA-RRSR must be followed.

The competitor must advise the organizer in writing of the reason for retirement (e.g. accident, technical problems, etc.) and the intention to have the car re-scrutineered **at the latest one**

hour before the publication to the start list of Leg 2. The car must report to the overnight Parc Fermé before the next Leg no later than 1 hour before the scheduled start of Leg 2. The new time for scrutineering will be 1 hour before the start of the 1st driver on Leg 2.

Penalties for retired Crews in Leg 1 will be applied as per article 54.2 of RRSR.

12.1.4 Start of special stages

The start to all special stages will be given by an electronic digital countdown system, counting down by seconds and clearly visible to the crew from the start position. This start line detection device is 50 cm after the start line in the height of 50 (+/- 5) cm. The car must be placed in such a way that its foremost part is on the level of the start line.

Light signals combined with a digital countdown system will be used:

-30 sec: the starter shows `30sec` signboard

-15 sec: the starter shows `15sec` signboard

-10 sec: the starter points on the starting countdown system

-5 ... -1 sec: red light segments will be switched on (second by second)

0 sec: START, the red light turns into the green

+20 sec: green light switches off, the Art. 48.4.3 of the FIA-RRSR will be applied.

In case of electronic digital countdown system breakdown, the car will be started on the instruction given by the Start Marshal according to Art. 48.3. of RRSR

12.2 Finish procedure

The competitive part of the rally ends in the Time Control at the entrance to the Podium (TC 13C). All crews of the rally will be awarded according to the art. 14.2 will be over-given on the finish ramp. After the ceremony, crews will get a new time card and they are obliged to go straight to the Parc Fermé according the time mentioned in the time card, and following the route described in the Roobook.

12.3 Permitted early check-in

Early arrival without penalty is permitted only at **TC TZ, TC 1A, TC 7C, 7D, Final Parc Fermé**

12.4 Special stages

12.4.1 SSS-Királyszentistván, Friday, 09 May 2025

SS1 is a superspecial stage formed in loop. Competitors shall leave the stage towards the finish after the laps – according to Road Book.

After checking in the TC crews must follow the marshals' instructions. Each car will be noted with a „RIGHT” or „LEFT” sign, which means the side of their starting position. Basically, the lower starting number will start on the right, higher number on the left, but the organizer keeps the right to change it.

12.4.2 Barriers

Due to safety reasons, barriers/anti-cut devices will be placed on the rally route and will be observed by judges of facts.

Barriers (chicanes) will be formed with tires, straw bales, or plastic barrels. Any crew which bypasses, skips, or moves away the barriers will be reported to the Stewards.

12.5 Service Park

12.5.1 Location and organization of service park

Place: Veszprém Arena parking place
GPS: N47° 06.336' E17° 56.044'
Date: According to Art.3.

Additional space can be ordered for a price of 15 € per 1 m².
Connection to electricity included in the entry fee with 3x16 Amper.
Any further energy request need to be noted by the Organizer at

rallyhungary@trpevents.hu. Fees (including all costs of the consumption and building a connection point at a maximum distance of 30 m from the Crew's service location):

- 3 x 32 Amper: 100 EUR
- 3 x 63 Amper: 200 EUR



In order to preserve the cleanliness of the Service Park, the organiser has the right to check the competitors' service area by Service Park marshals. When the competitor leaves his service area after the race weekend, he and his team must clean their service area from all the garbage.

In order to ensure this, during the administrative check every driver must pay **100 EUR deposit**. The deposit will be given back in case the driver's team left their service area clean, and the marshal who check the area gives the team a receipt, which proves that the area is clean and the environment is unharmed. This receipt shall be presented at the Rally Office during the opening hours of the office in order to receive the deposit back. After the closing of the Rally Office at the end of the weekend, the deposit is not refundable. In case of a common service with 2 or more drivers on the same service area, each driver gets their own receipt.

Driving in Service Park

During the service time between the first rally car enters and the last car leaves the service park, it is strictly forbidden for all service vehicles to enter or drive inside the service park. Every infringement will be sanctioned by the Clerk of the Course with a penalty of 100 €. The service park is one-way both for rally cars as well as the service and auxiliary vehicles. Maximum speed inside the service park is limited by 30 km/h.

12.5.2 Catering in the service area/park

If your team or any other company would like to have catering for their guests in the service area, it must be settled with the organizer before starting administrative checking. In other cases, organizers can forbid this catering. An exception is a food supply for crews and mechanics. Concerning waste disposal, the Organizer can levy a charge for costs. Selling food and drinks in the service area without the permission of organizers is strictly forbidden.

12.5.3 Shows and exhibitions in service area/park

If any team or company would like to organize shows or exhibitions for their guests in the service area, they must ask organizers for permission before administrative check. All shows and exhibitions in the service area without the permission of organizers are strictly forbidden.

12.6 Official time used during the rally

Official time throughout the entire rally GPS given time.

12.7 Entrance to the regrouping area and parc fermé

12.7.1 SAS Safety GPS tracking staff are allowed to enter the regrouping area and parc fermé to maintain or repair the GPS tracking systems installed in the rally cars. They have to be accompanied by a scrutineer and competitor or at least one representative of the team.

12.7.2 TV Crews, which will be published by the CoC information, are allowed to enter the regrouping area and parc fermé in order to maintain the camera systems installed in the rally cars or to exchange the data recording media. They have to be accompanied by a scrutineer and at least one representative of the team (driver, co-driver, and/or competitor).

12.8 Flexi Service

For the operation of 45' flexi-servicing, crews will enter the Parc Fermé. After a minimum 10 minutes stay crews may then either enter the Service Park or leave their car in the Parc Fermé. According to Art. 59.2.2 of the FIA-RRSR, the competing car may be driven by an authorized representative of the competitor only from the Parc Fermé to the Service Park (TC 7B "Parc ferme & Technical Zone - Out / Flexi Service - In") and vice versa (from TC 7C "Flexi service - Out" to TC 7D "Parc ferme - In") respecting all the formalities of time card presentation and related penalties. The competing car may be conducted to the overnight Parc Fermé before the 45 minutes have elapsed without penalty. All cars except re-starting crews must be in the overnight Parc Fermé no later than at 22:30.

12.9 Final scrutineering

Cars subject to final checks must have one representative of the entrant as well as mechanics present at the final scrutineering.

Subjected cars will be escorted from the finish podium to the place of the final scrutineering, and after it to the Parc Ferme.

12.10 Promoter Portrait for Competitors ERC

Photos will be taken in the rear hall of the HQ Rally on Thursday of 18:30 to 20:00h.

Participants should note the following:

- Photos will be taken on a first-come, first-served basis.
- The photo shoot is compulsory for all drivers and co-drivers, but more importantly, it will provide valuable material for the 2025 season, which will be used for promotion in print, online and on social media.
- Please come to the photo shoot in your official race suit, shoes and gloves (if applicable).

13. IDENTIFICATION OF OFFICIALS

Chief of SS	- red tabard
Chief of RCP/ SP	- yellow tabard
Timekeeper	- black jacket with orange inscription "Timing"
Route Marshals	- white tabard
CRO	- red jacket with inscription "CRO"
Scrutineer	- dark blue jacket with inscription "ATB"

14. CLASSIFICATION AND PRIZES

14.1.1 FIA Championship classifications

- FIA European Rally Championship for Drivers and Co-Drivers
- FIA European Rally Championship for Teams
- FIA European Rally Championship for Tyre Suppliers
- FIA ERC3 Championship for Drivers and Co-Drivers
- FIA ERC4 Championship for Drivers and Co-Drivers
- FIA Junior ERC Championship for Drivers
- FIA Master ERC for Drivers
- M-Sport Fiesta Rally3 Trophy

14.1.2 Classifications will be established following the FIA Regional Rally Sporting Regulations.

14.2 Prize-giving

Place: Finish ramp – Veszprém, Gyárkert

The prize-giving will take place on the 11th of May 2025. Following trophies will be awarded for:

FIA European Rally Championship for Drivers and Co-Drivers

1st place cups,

2nd place cups,

3rd place cups,

FIA European Rally Championship for Teams:

1st place cups

FIA Junior ERC Championship for Drivers and Co-Drivers

1st place cups

2nd place cups

3rd place cups

FIA ERC 3 Championship for Drivers and Co-Drivers

1st place cups

2nd place cups

3rd place cups

FIA ERC 4 Championship for Drivers and Co-Drivers

1st place cups

2nd place cups

3rd place cups

FIA Master ERC Championship for Drivers

1st place cups

2nd place cups

3rd place cups

M-Sport Fiesta Rally3 Trophy

1st place cups

2nd place cups

3rd place cups

FIA European Rally Championship for Tyre Suppliers

1st place cup

15. FINAL CHECKS AND PROTESTS

15.1. Final scrutineering of selected vehicles

Place: TBA

Date: 10 May 2025

Time: According to Art. 3.

15.2 Protest deposit

Defined: 1 000 €

15.3 Appeal deposit

The appeal deposit amount is published on the FIA website:

<https://www.fia.com/international-court-appeal>

The amount of the appeal deposit is determined in Article 10.1.2 of the Rules

All protests and/or appeals must be lodged in accordance with Articles 13 and 15 of the Code and, where applicable, with the FIA Judicial and Disciplinary Rules.

Appendix 1 - Itinerary

Qualifying						09 05 2025 Friday
TC/SS	LOCATION	SS dist. (km)	Liaison dist. (km)	Total dist. (km)	Target time (hr:min)	1st car due
Service OUT						
RZ	Refuel Area (Veszprém)					
QS	Distance to next refuel					
	Free practice opens					11:00
	Free practice close					13:00
QS	Hajmáskér					13:55
QS	Hajmáskér QUALIFYING STAGE	6,00			0:06	14:01
TZ	Technical Zone IN (Veszprém Aréna)		18,30	24,30	0:40	14:41

Shakedown						09 05 2025 Friday
TC/SS	LOCATION	SS dist. (km)	Liaison dist. (km)	Total dist. (km)	Target time (hr:min)	1st car due
Service OUT						
SD	Hajmáskér		11,77			15:10
SD	Hajmáskér SHAKEDOWN	6,00				15:13

LEG 1 (Section 1)						09 05 2025 Friday
TC/SS	LOCATION	SS dist. (km)	Liaison dist. (km)	Total dist. (km)	Target time (hr:min)	1st car due
0A	Service Area OUT (Tyre marking)					17:37
RA	Refuel Area (Veszprém)					
QS	Distance to next refuel					
1	Királyszentistván		12,6	12,6	0:25	18:02
SS 1	SSS Királyszentistván	2,05			0:03	18:05
1A	Parc Fermé IN (Veszprém, Early check in permitted)		14,92	16,97	0:30	18:35
Sunrise: 06:00 / Sunset: 19:27		SS dist.	Liaison dist.	Total dist.		
LEG 1 (Section 1) total:		2,05	27,52	29,57	6,93%	

Leg 1 Section 2, 3

Saturday 10 05 2025

TC/SS	LOCATION	SS dist. (km)	Liaison dist. (km)	Total dist. (km)	Target time (hr:min)	1st car due
1B	Overnight regroup		0,00	0,00		8:00
1C	Service IN		3,30	3,30	0:10	8:10
Service "A" (Veszprém Aréna)		2,05	30,82	32,87		
1D	Service OUT		0,10	0,10	0:15	8:25
RA 1	Refuel Area - VESZPRÉM ARÉNA Distance to next refuel	(18,75 km)	(69,74 km)	(88,49 km)		
2	Hegyese		44,85	44,85	0:50	9:15
SS 2	HEGYESD / 1	18,75				9:18
RA 2	Remote Refuel Area - AJKA Distance to next refuel	(34,60 km)	(87,80 km)	(122,40 km)		
3	Márkó		48,15	66,90	1:25	10:43
SS 3	KISLÓTÉR / 1	25,80				10:46
4	Várpalota		29,02	54,82	0:55	11:41
SS 4	VÁRPALOTA / 1	8,80				11:44
4A	Regrouping & Technical Zone in		35,37	44,17	0:52	12:36
Regrouping (Veszprém Aréna)						
4B	Regrouping out Service in		0,05	0,05	1:00	13:36
Service "B" (Veszprém Aréna)		53,35	157,54	210,89		
4C	Service OUT		0,10	0,10	0:30	14:06
RA 3	Refuel Area - VESZPRÉM ARÉNA Distance to next refuel	(18,75 km)	(69,74 km)	(88,49 km)		
5	Hegyese		44,85	44,85	0:50	14:56
SS 5	HEGYESD / 2	18,75				14:59
RA 4	Remote Refuel Zone - AJKA Distance to next refuel	(34,60 km)	(87,80 km)	(122,40 km)		
6	Márkó		48,15	66,90	1:25	16:24
SS 6	KISLÓTÉR / 2	25,80				16:27
7	Várpalota		29,02	54,82	0:55	17:22
SS 7	VÁRPALOTA / 2	8,80				17:25
7A	Parc Fermé & Technical Zone in		35,37	44,17	0:52	18:17
7B	Parc Fermé out / Flexi Service in		0,05	0,05	0:10	18:27
Flexi Service "C" (Veszprém Aréna)		53,35	157,44	210,79		
7C	Flexi Service out		0,10	0,10	0:45	19:12
7D	Parc Ferme IN		2,95	2,95	0:10	19:22
<i>Early check-in permitted</i>						
<i>All cars must be returned to Parc Fermé no later than:</i>						22:30
Saturday totals 6 GY / 6 SS		108,75	346,00	454,75		11:12

Section 2

Section 3

TOTALS OF THE RALLY						
	GY/SS	etap /	liaison	össz./	total	%
Saturday 10 th May 2025	108,75	346,00		454,75		23,91%
Sections 2,3						
Total: 6 SS	108,75	346,00		454,75		23,91%

Leg 2 Section 4, 5, 6

Sunday 11 05 2025

TC/SS	LOCATION	SS dist. (km)	Liaison dist. (km)	Total dist. (km)	Target time (hr:min)	1st car due
7E	Overnight regroup OUT		0,00	0,00		8:25
7F	Service IN		3,30	3,30	0:10	8:35
Service "D" Veszprém Aréna		0,00	6,35	6,35		
7G	Service OUT		0,10	0,10	0:15	8:50
RA 5	Refuel Area - VESZPRÉM ARÉNA Távolság a köv. Tankoló zónáig / Distance to next refuel	(41,13 km)	(120,83 km)	(161,96 km)		
8	Iszka		35,10	35,10	0:34	9:24
SS 8	ISZKA / 1	15,34				9:27
9	Tés		37,60	52,94	1:05	10:32
SS 9	TÉS / 1	10,25				10:35
10	Nagylőtér		27,78	38,03	0:50	11:25
SS 10	NAGYLÓTÉR / 1	15,54				11:35
10A	Regrouping & Technical Zone IN		20,15	35,69	0:45	12:20
Regrouping (Veszprém Aréna)						
10B	Regrouping out Service in		0,10	0,10	0:32	12:52
Service "E" Veszprém Aréna		41,13	120,83	161,96		
10C	Service OUT		0,10	0,10	0:30	13:22
RA 6	Refuel Area - VESZPRÉM ARÉNA Távolság a köv. Tankoló zónáig / Distance to next refuel	(41,13 km)	(135,44 km)	(176,57 km)		
11	Iszka		35,10	35,10	0:34	13:56
SS 11	ISZKA / 2	15,34				13:59
12	Tés		37,60	52,94	1:05	15:04
SS 12	TÉS / 2	10,25				15:07
12A	Regrouping IN		28,81	39,06	0:50	15:57
Regrouping (Veszprém Aréna)						
12B	Regrouping OUT				0:50	16:47
13	Nagylőtér		10,30	10,30	0:15	17:02
SS 13	NAGYLÓTÉR / 2 - POWER STAGE	15,54				17:05
13A	Regrouping & Technical Zone IN		20,15	35,69	0:45	17:50
Regrouping (Veszprém Aréna)						
13B	Regrouping out Service in		0,10	0,10	0:10	18:00
Service "F" Veszprém Aréna		41,13	132,06	173,19		
13C	Service OUT		0,10	0,10	0:15	18:15
13D	Podium IN (Veszprém Gyárkert)		2,40	2,40	0:10	18:25
Prize giving / Finish Podium						(18:30)
13E	Podium OUT (Veszprém Gyárkert)		0,10	0,00		
13F	Parc Ferme IN		0,88	0,88		
Early check-in permitted						
Sunday totals 6 GY / 6 SS		82,26	261,74	344,00		10:00

Section 4

Section 5

Section 6

TOTALS OF THE RALLY

	GY/SS	etap /	liaison	össz./ total	%
LEG 1 - Section 1	2,05	27,52		29,57	6,93%
LEG 1 - Section 2, 3	108,75	346,00		454,75	23,91%
LEG 2 - Section 3, 4, 5	82,26	261,74		344,00	23,91%
Total - 13 SS	193,06	635,26		828,32	23,31%

Appendix 2 – Reconnaissance

Thursday, 08th May 2025

07:00-20:00

SS 2 / 5 Hegyesd

SS 8 / 11 Iszka

SS 9 / 12 Tés

SS 10 / 13 Nagylőtér

13:30-20:00

SS 4 / 7 Várpalota

14:00 – 19:00

SS 3 / 6 Kislőtér

19:00 – 22:00

SS1 – SSS Királyszentistván

Friday, 09th May 2025

07:00- 12:00

QS / Shakedown Hajmáskér

SS 2 / 5 Hegyesd



SS 3 / 6 Kislőtér

Maximum speed allowed during Reconnaissance is 70 km/h on special stages, unless a lower speed limit is indicated by traffic signs or by written instructions in the Road Book or Bulletin.

Appendix 3 - CROs – names, photographs and duties schedule

The principal duty of the CRO is to provide information or clarifications in connection with the regulations and the running of the rally to the competitors/crews. There must be at least one at each rally who must be easily identified by the competitors or crews and shall be present according of the CRO schedule. This schedule of their duties will be posted on the Official notice board of the rally.

Competitor's relations officer for ERC:

 <p>Julianna Nyirfás</p> <p>Spoken languages: English, Hungarian</p> <p>Phone: +36 30 606 9479</p>	 <p>Szabolcs Magyar- Beck</p> <p>Spoken languages: English, Hungarian</p> <p>Phone: +36 30 337 6443</p>
---	---

Schedule of presence of Competitors Relations Officers will be communicated by a CoC Communication before the Rally

Appendix 4 - Competition numbers and advertising

1. The organiser reserves following places which must remain free according to this drawing:

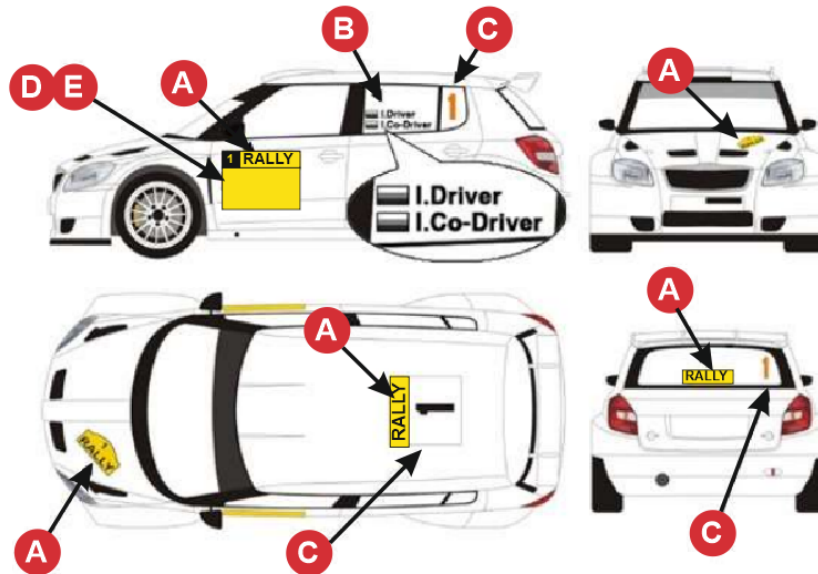

1.1 Compulsory advertising

- A – Rally plates
- B – Driver's and Co-driver's names
- C – Competition number

1.2 Optional advertising proposed by organiser / TBC

The organiser reserves following places which must remain free:
D, E - panel 67 x 20 cm under the side door starting number

1.3 ERC Compulsory advertising

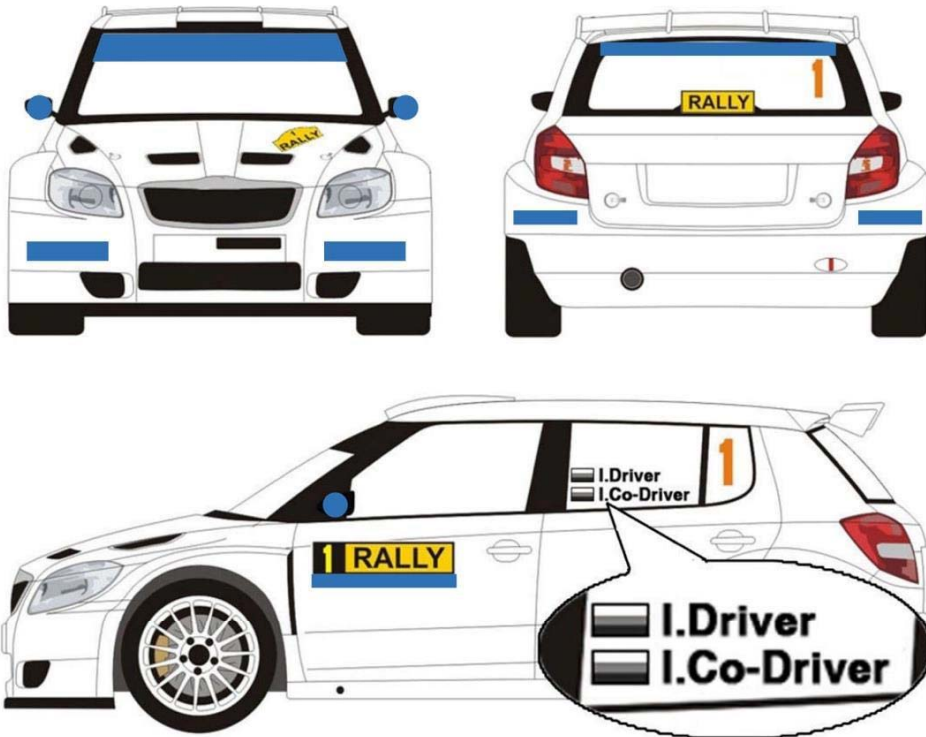

A 15cm strip on the front windscreen of each rally car, including 0 cars



2 side mirror stickers on each rally car



ERC strip below the rally plate on each door of the competing car



2 strips on both front and rear bumpers for tyre supplier



A 8cm strip on the rear windscreen (top) of each rally car

Appendix 5 – Extracts from FIA ISC Appendix L relating to overalls, helmets and any other safety requirements

All competitors are reminded of Appendix L of the FIA International Sporting Code, in particular its Chapter III - Drivers' Equipment.

Helmets (Appendix L, Chapter III, Art. 1)

All crews must wear crash helmets homologated to one of the following FIA standards:

- 8859-2015 (Technical List N°49),
- 8859-2024 or 8859-2024-APB (Technical List N°107),
- 8860-2010 (Technical List N°33), or
- 8860-2018 or 8860-2018-ABP (Technical List N°69)

Frontal Head Restraint (FHR, Appendix L, Chapter III, Art. 3)

All crews must use FIA approved FHR systems homologated to FIA standard 8858.

Approved FHRs, anchorages and tethers are listed in Technical List N° 29.

See also helmet compatibility chart in Appendix L, Chapter III, Art. 3.3.

Flame-resistant clothing (Appendix L, Chapter III, Art. 2)

All drivers and co-drivers must wear overalls as well as gloves (optional for co-drivers), long underwear, a balaclava, socks and shoes homologated to the FIA 8856-2018 standard (Technical List N° 74).

Drivers and co-drivers can wear additional FIA-approved personal underwear, between their skin and the compulsory FIA-approved underwear. No other underwear is permitted.

Please pay special attention to the prescriptions of Art. 2 concerning embroidery and printing on flame-resistant clothing (manufacturer certificates etc.) **as well as concerning the correct wearing of the clothing elements! See also Regional Rally Sporting Regulations, Article 53.1.**

Biometric Devices (Appendix L, Chapter III, Art. 2.1)

Drivers may wear a device to collect biometric data during racing.

- If the biometric device is integrated into a protective garment homologated to FIA Standard 8856, the garment shall be homologated to FIA Standards 8856 and 8868-2018.
- If the biometric device is a stand-alone device, then the device must be homologated to FIA Standard 8868-2018 only. This device must be worn in addition to the garment homologated to FIA Standard 8856.

Wearing of jewellery (Appendix L, Chapter III, Art. 5)

The wearing of any type of jewellery, such as but not limited to, neck chains, bracelets or watches is prohibited during the competition. Exceptions to this rule, providing the CMO and/or Medical Delegate do not consider that due to size or location they may delay rescue or hinder emergency care, are:

- the wearing of watch(es) by co-drivers, on the condition that the watch(es) is worn over the overall.
- the wearing of a single band-style ring providing it does not restrict the natural range of motion of the hand.
- the wearing of body piercing(s) providing they are not worn in and/or around the oral cavity.

RELATED LINKS:

FIA International Sporting Code and appendices: <https://www.fia.com/regulation/category/123>

FIA Technical Lists: <https://www.fia.com/regulation/category/761>

Appendix 6 – SAS FITTING KIT MANUAL – RALLY CAR

This manual is provided as a guide for the installation of the SAS Tracking System Kit, for competition vehicles only. Care should be taken when considering the location of components with regard to electrical cabling and fire suppression systems already installed in the vehicle. Please check always that the components of your kit are as requested.

1. Tracking Unit Kit Components & Steps

The Tracking System Kit includes:

- SAS Tracking Installation and Fitting Kit Instruction Sheet;
- 3-in-1 antenna with leads;
- Internal radio antenna with lead;
- 6 – 24v wiring loom with plug;
- Mount, to be bolted to tunnel;
- Adjustable mount connector/knuckle.



(Contents may differ slightly to image shown)

SAS tracking system fitment steps:

1. Mount SAS tracker;
2. Fit external & internal antennas, running leads to the SAS tracker;
3. Fit wiring loom, ensuring that a solid 9 to 28 volts is supplied;
4. Connect all antenna connections, make sure they are tight using an 8mm spanner;
5. Apply power.

2. Power Supply

SAS tracking system requires a reliable power supply from 9 to 28 volts DC. We recommend a 5 amp (Max) blade type or similar quality fuse is used at the battery supply end of the SAS tracking system power lead.

Zero volts or battery negative can be picked up at any suitable earthing point providing the isolation switch does not switch the negative side of the battery.

The SAS tracking system unit has an internal battery that is kept charged via the car's power supply. It acts as a reserve supply to power the unit in the case of an accident where a car's power supply is interrupted (e.g. car battery smashed or dislodged).

Note: The tracking device should only be powered once it is placed in its final position in the vehicle; this ensures accelerometers are calibrated correctly.

3. Connection Diagram

The 6-24v wiring loom, includes five wires. The white blue and grey wires must be stagger cut and heatshrunk or taped back so they cannot short to ground or to each other. Red and black are used as follows

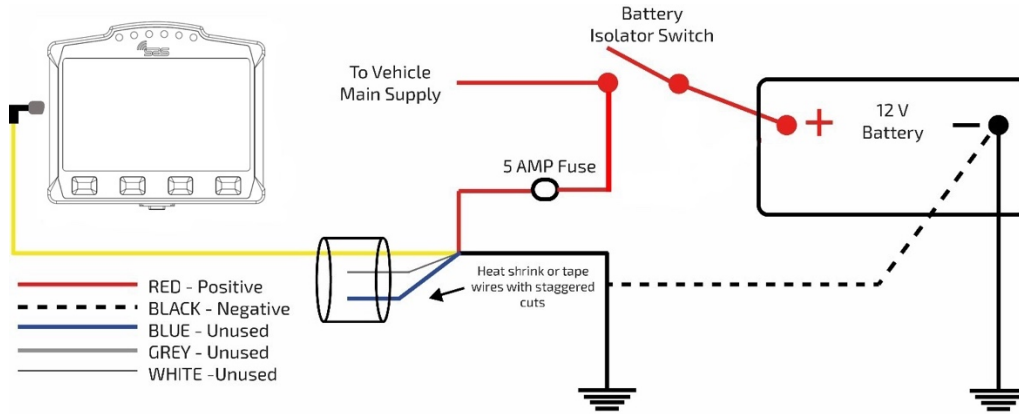

RALLYSAFE 12V WIRING DIAGRAM

During installation, the wiring loom should be routed away from the engine compartment, Ignition or Alternator wiring.
300 mm of Power Supply Wiring Loom is required to be available for connection to the SAS Tracker Unit at the mounted position

4. Connection Diagram

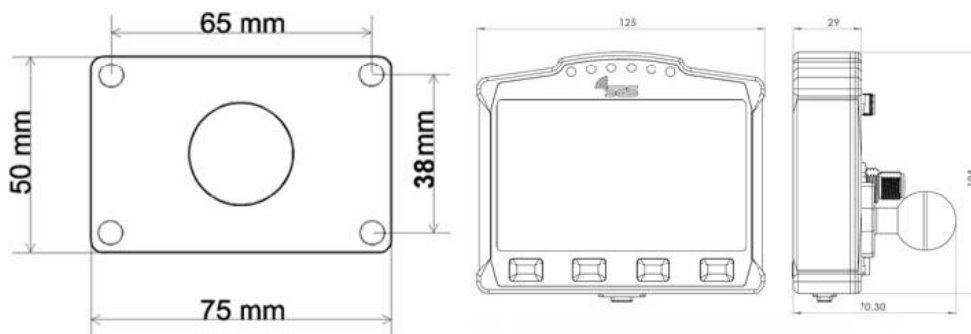

5. Tracking Unit Mounting

The preferred location and mounting for the SAS tracking system unit is a RAM style 50mm x 75mm flatbase with ball, bolted through the tunnel with four M6 Bolts.

It should be in a central, protected location on the central tunnel in front of the seats and both easily visible and accessible by both the driver and co-driver/nav.

Care should be taken when considering the location of the Mounting Point with regard to electrical cabling and fire suppression systems installed in the vehicle.

Photographs of mounting and positioning can be seen in Fig.1 and Fig.2 respectively.

Alternatively, the SAS tracking system unit can be mounted in a central protected location on the vehicle dashboard that is easily visible and accessible by both the driver and co-driver.

Mounting is a Ram style 50mm x 75mm flat base with ball, bolted with four M6 bolts through the dashboard and a compulsory 3mm backing plate measuring no less than 145mm x 120mm



Figure 1. 25mm rubber ball securely attached to the tunnel



Figure 2. The WRC tracking unit mounted onto the 25mm rubber ball mount and connected through the RallySafe connector

6. Antenna Installation

All leads on both external and internal antennas must run on the inside of all roll cage bars. This is to stop cable crushing on impact.

Antenna must not be mounted within 200 mm of any high frequency antenna's or cabling

The preferred route is to go down from the antenna, underneath the closest part of the roll cage (roof cross or main hoop), follow that along to the roof hoop, then go down the inside A pillar to the unit. Please allow 200mm clearance of high frequency antenna or cabling

Any excess cable must be run so that the cable is not bent any tighter than a 100mm radius. We recommend running it across the underside of the dash and back (do not coil in tight loops).

Cables must be tied neatly along the whole installation all the way to the unit so they can't be accidentally caught or dislodged.

All this will be checked at scrutineering and you may be required to fix it before your car can pass.

Note: All antenna connections need to be firmly tightened with an 8mm spanner.

7. External Antenna

The antenna is mounted through a 12mm hole in a central location on the ROOF of the vehicle, rear of the main roll bar hoop, allowing the cabling to pass through the roof and follow the cage bars back to the unit location. The antenna is a fully watertight unit, which seals against the roof surface.



Antenna leads are connected as follows (There may be variations with the type and number of leads):

1. The 2 WiFi leads, colour-coded **Blue**, is connected to the terminal labelled "WiFi" on the SAS unit (Right Hand Thread). Terminals are located of the rear of the unit and/or colour-coded Blue.
2. The Satellite Communication antenna lead is connected to the centre or rear terminal labelled "IRI" (Left Hand Thread). It may also be colour-coded **Yellow** (this may be not marked on the 2-in-1 antenna).
3. The GPS antenna lead labelled "GPS", is connected to the terminal labelled "GPS" on the SAS unit (Right Hand Thread). Terminals may be on the side or rear of the unit and/or colour-coded **Green**.
4. GSM, has a small stick antenna supplied with the SAS unit, and is connected to corresponding terminal labelled "GSM" on the SAS unit (Left Hand Thread). The terminal is located on the rear of the unit and/or colour-coded **Red**.

8. Internal Antenna

The Internal Antenna should be placed on the inside of the ROOF in a clear uncluttered area, with a 200mm radius clear of any bar work or solid metal object. The internal antenna has a magnetic base with double-sided tape for adhesion. The cable is then run to the SAS unit. Please keep cable on the inner side of the rollcage pipework so as not to be crushed in the event of an accident.

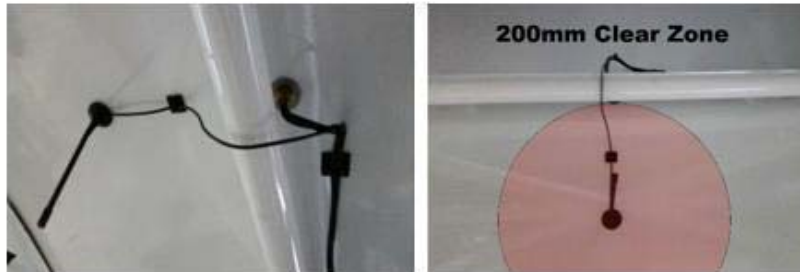

Figure 3. The internal antenna must be at least 200mm away from any roll cage components

9. Contact Us

For assistance, please contact the RallySafe Support Team by emailing: support@rallysafe.com.au

Product Disclaimer

"This manual, the specifications, and the material contained in it, as released by Status Awareness Systems and RallySafe, is for the purpose of information only. Due to continuous ongoing development, information and specifications may change at any time without notice. SAS, and the companies that have contributed to it, shall not be liable for any use of the manual or information supplied.

The material contained in this manual is protected by copyright and other types of Intellectual Property Rights. The commercial exploitation of the material contained in this specification requires a license to such Intellectual Property Rights.

This manual may be utilised or reproduced without any modification, in any form or by any means, for informational purposes only. For any other purpose, no part of the specification may be utilised or reproduced, in any form or by any means, without permission in writing from SAS.

The word RallySafe and the RallySafe logo are registered trademarks".